BYQ5kVA Hipot Tester

User Manual

warn

[please read this manual carefully and keep it for future reference or maintenance]

Dear Client

Thank you for purchasing our BYQ5kVA Hipot Tester. Please read the manual in detail prior to first use, which will help you use the equipment skillfully.



Our aim is to improve and perfect the company's products continually, so there may be slight differences between your purchase equipment and its instruction manual. You can find the changes in the appendix. Sorry for the inconvenience. If you have further questions, welcome to contact with our service department.



The input/output terminals and the test column may bring voltage, when you plug/draw the test wire or power outlet, they will cause electric spark.

PLEASE CAUTION RISK OF ELECTRICAL SHOCK!

🕒 **SERIOUS COMMITMENT**

All products of our company carry one year limited warranty from the date of shipment. If any such product proves defective during this warranty period we will maintain it for free. Meanwhile we implement lifetime service. Except otherwise agreed by contract.



SAFETY REQUIREMENTS

Please read the following safety precautions carefully to avoid body injury and prevent the product or other relevant subassembly to damage. In order to avoid possible danger, this product can only be used within the prescribed scope.

Only qualified technician can carry out maintenance or repair work.

--To avoid fire and personal injury:

Use Proper Power Cord

Only use the power wire supplied by the product or meet the specification of this produce.

Connect and Disconnect Correctly

When the test wire is connected to the live terminal, please do not connect or disconnect the test wire.

Grounding

The product is grounded through the power wire; besides, the ground pole of the shell must be grounded. To prevent electric shock, the grounding conductor must be connected to the ground.

Make sure the product has been grounded correctly before connecting with the input/output port.

Pay Attention to the Ratings of All Terminals

To prevent the fire hazard or electric shock, please be care of all ratings and labels/marks of this product. Before connecting, please read the instruction manual to acquire information about the ratings.

Do Not Operate without Covers

Do not operate this product when covers or panels removed.

Use Proper Fuse

Only use the fuse with type and rating specified for the product.

Avoid Touching Bare Circuit and Charged Metal

Do not touch the bare connection points and parts of energized equipment.

Do Not Operate with Suspicious Failures

If you encounter operating failure, do not continue. Please contact with our maintenance staff.

Do Not Operate in Wet/Damp Conditions.

Do Not Operate in Explosive Atmospheres.

Ensure Product Surfaces Clean and Dry.

—Security Terms

Warning: indicates that death or severe personal injury may result if proper precautions are not taken

Caution: indicates that property damage may result if proper precautions are not taken.

Catalog

I Overview	5
II Structure	5
III Working principle	6
IV How to use	8
V. Announcements	12
VI Matching products	13
VII. Capacity choice of testing transformer	14

I Overview

BYQ5kVA Hipot Tester has the characteristics of small volume, light weight, compact structure, functional, strong commonality and convenient use, etc. Especially suitable for power system, industrial and mining enterprises, scientific research departments and all kinds of pressure electric equipment, electric components, insulation material or DC power frequency dielectric strength under high-voltage test. It's essential for high-voltage test equipment.

II Structure

BYQ5kVA Hipot Tester uses the single frame iron core structure. First circle resistance rolls on the iron core and high voltage outside. This axial structure reduces the magnetism leakage and rises the coupling of the circle resistance.

The hull of the production is made as octagonal which can well match the core structure. The whole appearance looks elegant. Its inside structure graph and outside structure graph are as below.

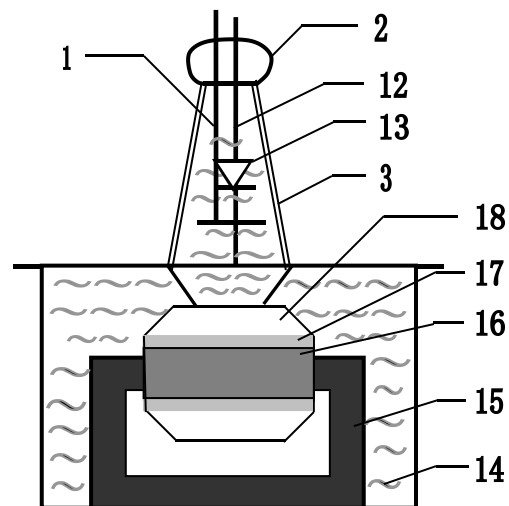
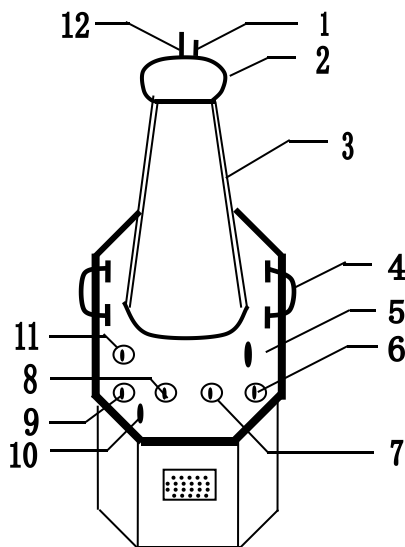

1-short circuit rod D

3-high voltage casing pipe

5-oil valve

8~9-testing port E、 F

2- voltage sphere

4-transformer handle

6~7 primary voltage input a, x

10-grounding hull of transformer

11-high voltage end X	12-high voltage output A
13-high voltage silicon stack	14-oil of transformer
15-iron core	16-primary low voltage winding
17-testing winding	18-secondary HV winding

In the BYQ5kVA Hipot Tester, a and x are low voltage input port, E,F are meter measuring port, A,X are high voltage output.

III Working principle

BYQ5kVA Hipot Tester is a single phase transformer, with power frequency of 220V (10kVA for 380V). Power connects to XC/TC (our professional product for testing transformer, its details refer to the operation manual) series operation box, through inside the auto-transformer voltage adjuster (50kVA or more outside) to 0-200V (or 0-400V). The voltage outputs to BYQ5kVA Hipot Tester's first windings. Based on the principle of electromagnetic induction, we can get the proper high voltage when testing the high voltage winding.

1. The working principle of the Single BYQ5kVA Hipot Tester are shown in Figure 3

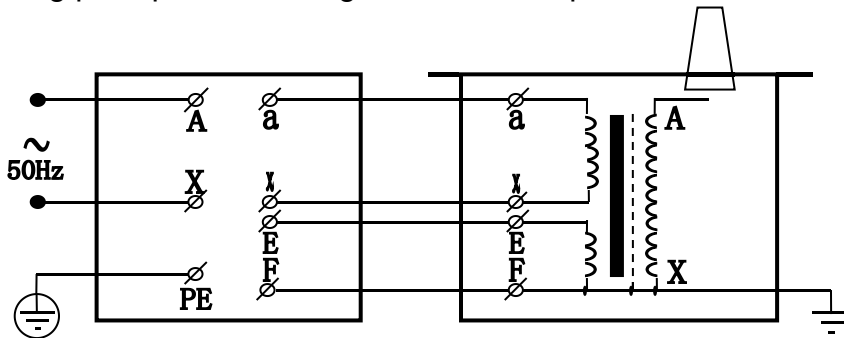

2. The working principle of the Single BYQ5kVA Hipot Tester Set are shown in Figure 4, The high voltage fuse equipped with HV silicon stack, cascading in the high voltage circuit for half-wave rectification to get high voltage current. When using a short circuit rod to short the high voltage silicon stack, it can get the power frequency high voltage, as the state of AC. When you cancel the short circuit rod, it is in the state of DC.

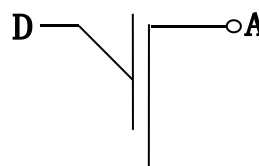

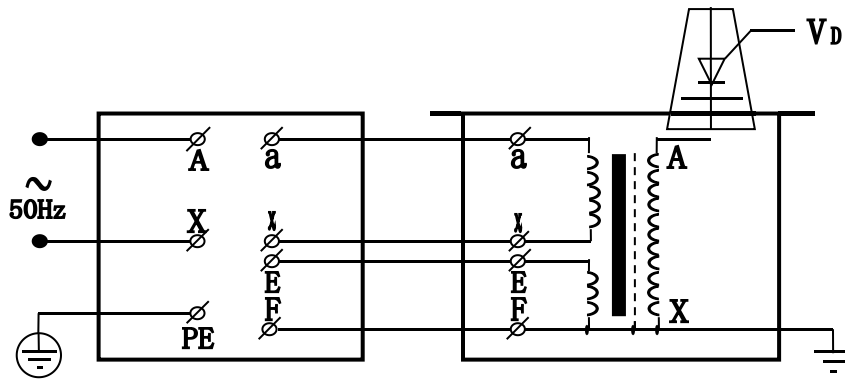

Figure4: Single Withstanding High Voltage Test Set principle diagram
D—short-circuit rod VD—high-voltage silicon

3. Three testing transformers cascading together can get higher voltage and its principle as below. The cascading high voltage testing transformer has great advantage for the whole machine is consisted of several single testing transformers, single transformer capacity is small, with low voltage, light, portable and easy to install. It can cascade to a great capacity HV testing transformer from several small ones and also can be used individually. The whole equipment is economy. In the graph, every testing unit in the first and second class testing transformer has a excitation winding A1, C1 and A2, C2. In the cascading class testing transformer's principle graph, low voltage power added to the testing transformer I first winding a1x1, single testing machine I, II, III output voltage are V. Excitation winding A1, C1 provide power to the second class testing transformer II and third class circle transformer III with voltage of 1V and 2V compared to the ground. So the hull should be insulating, the testing transformer I hull should be connected to the ground. So the first, second and third class voltage are 1V, 2V, 3V compared to the ground. Their capacities are 3P, 2P, 1P.

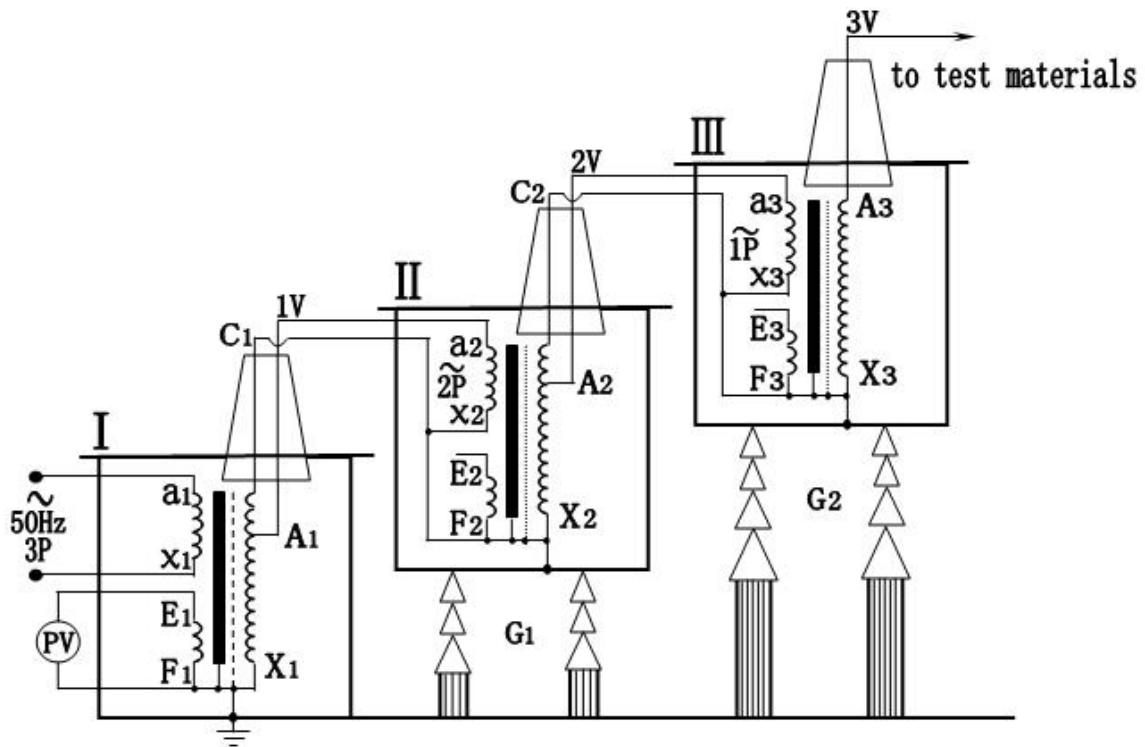

Figure 5

P—capacity(kVA)

V—voltage(kV)

G1、G2—insulation support

IV How to use

1. Withstanding High Voltage Test Set power frequency withstand voltage circuit principle graph as below:

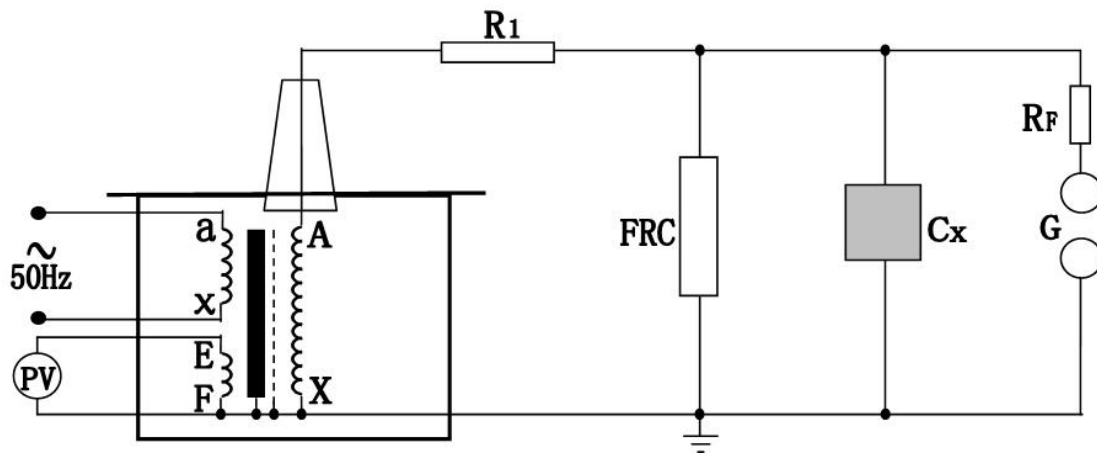

Figure6

R1- limit current resistance

RCF-resistance-capacitance voltage divider

RF-sphere gap protective resistance

G-sphere gap CX-measured equipment

Addition: high voltage end must be well connected to the ground.

Addition: high voltage end must be well connected to the ground.

In the power frequency withstand voltage testing, limit current resistance R_1 depends on the capacity of the testing transformer. For example, the high voltage rated output current is 100-300mA, we can make it $0.5-1 \Omega / V$, if it was above 1A, we can make it $1 \Omega / V$. Usually we take water resistance as the limit current resistance, the length of the pipe can be made as 150kV/m. The pipe should have the thermo-capacity (method of water resistance: use pure water added with cuprum solution)

Sphere gap protective resistance: when the voltage surpass a certain value(usually between 110% - 120% testing voltage), it discharge between the sphere gap and protect the tested staff. The resistance of sphere gap protective resistance can be made as $1 \Omega / V$.

In the testing of power withstand voltage, low voltage end measure the voltage not exactly, because there is leakage in the testing transformer. So there must be some voltage reducing or capacity rising to make the measured equipment voltage higher or lower than the voltage on the meter. In the power withstand voltage testing, the measured equipment high voltage must be higher than the output voltage of testing transformer, so it is capacity rising phenomenon. In the response withstand voltage testing, the testing transformer's leakage must have voltage reducing.

To get more exact measurement on voltage measured equipment, we usually add RCF resistance-capacitance at high voltage to divide the tested voltage.

Announcements on the power withstand testing operation:

(1) Tester should well divide their work, make clear the way of intercommunication.

And there must be people special for the safety and condition of measured equipment.

(2) The measured equipment must be pure dry and cleared in advance to avoid any

fault in the testing.

(3) For some mass testing, it usually tests up in the air, which is adjust meters and sphere gap before voltage rising.

(4) The speed of rising voltage cannot be too fast, and must avoid a sudden rising. For example, turn on when the transformer is not on the “zero”. And it also can be cut off at once; we usually turn off when the adapter is “zero”.

(5) When the voltage rise to the tested voltage, time counting should begin and after 1 min, reduce the voltage to 1 / 3, then we can turn on.

(6) At the process of voltage rising, if there any unfair conditions as below, we should stop rising and cut off the power. 1, the indication of voltage meter move too quick; 2, there is insulation burned and smoke; 3, there is unfair sound in the tested staff.

(7) Before withstand voltage testing, we should check the insulating resistance.

2. During the test, the working principle according DC withstand voltage and leakage testing as follow.

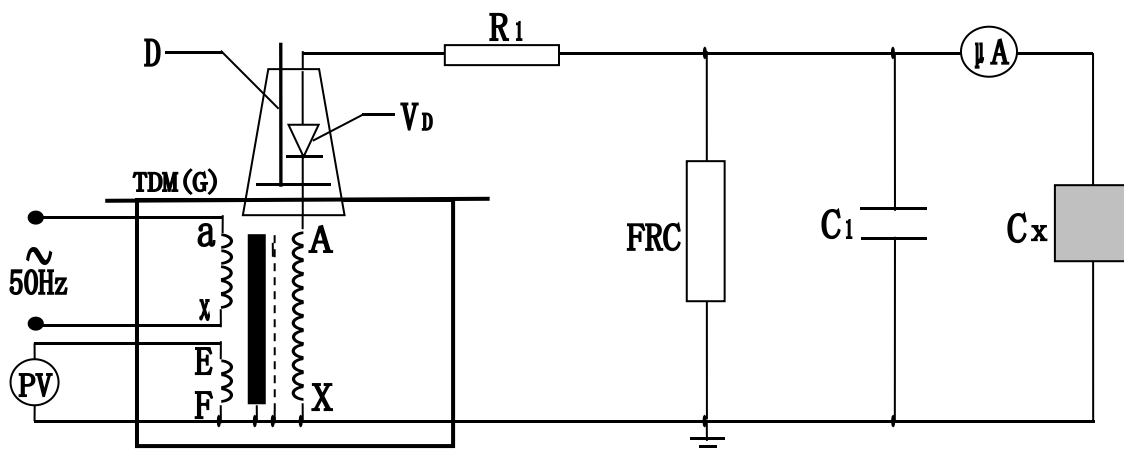

Among it, VD – high voltage silicon stack

R1 – limit current resistance

C1 – high voltage filtering capacity

RCF – resistance-capacitance divider

CX –measured equipment

uA – micro amp meter with protection

In the leakage testing, limit current resistance R1 as the output voltage, the output

short circuit current should not surpass the maxim current in the high voltage silicon stack. For example, the maxim current is 100mA for the 60kV measured equipment, the limit current resistance $R1=60/0.1=600k\ \Omega$. And there should be enough capacity and distance to discharging. The high voltage filtering capacity C1 range is 0.01–0.1uF. When the capacity of measured equipment is very big, C1 cannot be neglected.

Announcements in the leakage testing:

- (1) Before testing, we should make sure that the measured equipment was power off, grounding discharging, each line is clear. It must avoided that any voltage added to any place where people working.
- (2) After completing the circuit, we should inject voltage after seriously check. We should pay special attention to the distance between high voltage equipment, lines and ground and people. And make sure the hull of the measured equipment is well connected to the ground, and do every operation as ordered.
- (3) Boosting voltage slowly to the equipment with mass capacity to avoid the measured equipment and micro amp meter burned. If necessary, we should boost the voltage class by class and read the data individually from micro amp meter.
- (4) During the test, we should pay special attention to the measured equipment, test instrument, micro ammeter, stop boosting voltage one there was breakdown, flashover, power off and find out the reason, take record.
- (5) After testing, step down voltage and cut off the power, we should make sure that the measured equipment is completely discharged.

V. Announcements

1. Complete the circuit as you expected. The hull of testing transformer and operation system must be well connected to the ground. Testing transformer' high voltage X end and measured winding F end must be well connected to the ground.
2. In the cascading testing, the low voltage of second and third testing transformer's is X end, winding F end and HV winding X end must be connected to the hull of transformer. The second and third transformer's hull must be connected to the ground through insulating frame.
3. Before power on, the adapter must be on the "zero" and then can turn on and boost voltage.
4. Sooth boosting the voltage through the regulator hand wheel from zero. The methods: quick rising (20s); slow rising (60s); extreme slow rising. After rising the voltage to 75% of your target voltage, we should boost by 2% per second until to the target one. At the same time monitor the measured equipment and instrument. In the process of boosting, if there is any abnormal phenomenon, we should cut off the power or step down the voltage at once.
5. After testing, we should step down the voltage in several seconds to the zero and power off.
6. This production cannot be used in the other parameter which in not allowed. Except necessity of testing, get on the power or cut off is not allowed.
7. In the high voltage testing, not only get the operation manual familiar but also obey to the national standard.

VI Matching products

1. Operating system

BYQ5kVA Hipot Tester operating cabinet

Capacity: 1kVA~5kVA input voltage: 0.22kV

BYQ5kVA Hipot Tester operating console

Capacity: 10kVA~300kVA input voltage: 0.22kV 0.38kV

2. The protection of digital micro-amp 0-1999 μ A

3. RC-type AC-DC voltage divider FRC—50、100、150、200kV

4. High voltage DC discharge rod FD—70、140、210kV

5. High-voltage silicon 2DL—150、300、450kV

6. Insulation Support 50、100、200、300kV

7. High-voltage filter capacitor 0.01 μ F~0.1 μ F, 40~100kV

8. End shielding

9. Sphere gap Q—50、100、150、200、250、500

10. Standard Test Cup 400ml

11. Medium Oil Cup

12. Wheelbarrow Type 150、300

13. Water resistance

14. High voltage electroscope 10、35kV

15. High voltage phasing device 10、35、110、220kV

16. All kinds of multi-meter, mega meter and testing wire

VII. Capacity choice of testing transformer

The formula to testing transformer capacity is

$$P_n = KV_n^2 \omega C_t \times 10^{-9}$$

Among it: P_n ---standard testing transformer capacity (kVA)

V_n ---effective value of the testing transformer rated output

K ---- Safety factor. $K \geq 1$, standard voltage $V_n \geq 1\text{MV}$, $K=2$, standard voltage is low, K can be higher.

C_t ---capacity of the measured equipment

ω ----angular frequency, $\omega = 2\pi f$, f =frequency of tested power

The tested capacity C_t can be measured by AC Bridge. C_t varies greatly; it can be defined by the type of equipment. Some model data are as below:

Simple bridge or suspended insulator element micrometer method;

Simple classify of casting pipe 100-1000PF;

Voltage mutual inductor 200 – 500PF;

Electric power transformer < 1000kVA	1000PF
> 1000kVA	1000 – 10000PF;

High voltage power cable and oil immersed insulating 250 – 300PF/m;

Air insulating - 60PF/m;

Seal converting station SF₆, air insulating 100 – 10000PF;

For different testing voltage V_n , we should choose different or proper safety factor K . Below for reference.

$V_n = 50\text{--}100\text{kV}$ $K=4$

$V_n = 150\text{--}300\text{kV}$ $K=3$

$V_n > 300\text{kV}$ $K=2$