

# **BYQ5kVA Hipot Tester**

## **User Manual**

## Warning and attention

In order to avoid electric shock or personal safety, and in order to avoid damage to instruments or equipment under test, users are reminded to exercise reliable control and reasonable use, and the following principles must be observed at all times:

The test transformer must be grounded before turning on the power supply!

No access to power before grounding!

## Directory

- I. Product Profile
- II. General technical indicators
- III. The main technical parameters
- IV. Working principle
- V. Instructions
- VI. Precautions
- VII. Accessories

### I、Product Profile

Compared with oil-immersed transformers of similar products, this series of transformers, using advanced production equipment, adopt new technology of coil epoxy vacuum pouring and CD iron core, obviously reduce weight and volume. The insulation strength and moisture resistance are improved in quality, and the magnetic leakage is weakened effectively.

This series of products has the characteristics of light weight, small volume, beautiful shape, stable performance, easy to use and carry, especially suitable for field operation. It is a new type of AC / DC dual-purpose high-voltage test transformer in China. This series of generators is suitable for all kinds of high voltage power supply in power system and electric power users to test the insulation performance of various electrical equipment, DC high voltage and small current of electrical products.

## II. General technical indicators

- 1 Output voltage waveform: sine wave.
- 2 Output waveform distortion rate : $\leq 1\%$ .
- 3 No-load current and loss: execute according to national standard
- 4 Inductive withstand voltage level:  $1.1U_0/1\text{min}$ .
- 5 Short circuit impedance of 5 test transformers : $4.5\% \sim 12\%(\pm 10\%)$ .
- 6 Voltage adjustable accuracy is  $\pm 1\%$ .
- 7 Voltage instability is less than 1%.
- 8 over voltage protection function.
- 9 Surface temperature rise : $< 55^\circ\text{C}$
- 10 Under the rated capacity, the allowable continuous running time is 0.5 hours  
(long time required operating transformer, can be customized) ,
- 11 Intermittent running time:  
Below 10kVA, every 2 hours, allow continuous operation for 0.5 hours  
Above 15kVA, every 4 hours, allow continuous operation for 0.5 hours
- 12 At half rated voltage and half rated current, continuous operation is allowed for 4 hours

## III. The main technical parameters

1. Rated capacity:	5kVA
2. Rated input voltage:	200V
3. Rated input current:	25A
4. Testing voltage:	50kV
5. Rated output current:	0.1A
6. Instrument voltage:	100V
7. Working time:	1 h
8. Weight:	38kg
9. Dimensions:	380X280X600(mm)

## IV. Working principle

The input voltage of this series of products is 200V ,Use the principle of electromagnetic induction to change the input voltage as needed, The output high voltage can be continuously adjusted from zero volts to the rated value.

When doing DC withstand voltage and leakage current tests,Just spin the high-voltage silicon stack on the high-voltage output,to change the input voltage So as to obtain different values of DC high voltage output.

The specific working principle of this series of products is shown in Figure (1),  
When used as a cascade, its wiring is shown in Figure (2).

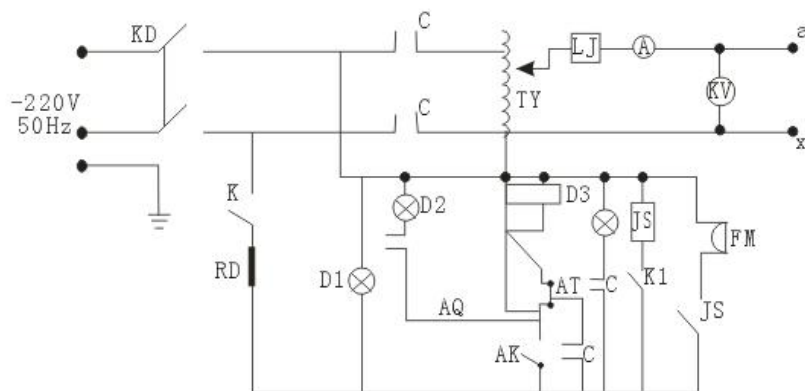

Figure (1)

BYQ3kVA:Hipot Tester

TY: Autocoupler

LJ: overcurrent relay

C: AC contactor

K: main power switch  
switch

AK: regulator return zero limit switch

CL: stop button

stack

A: output ammeter

JS: time relay

FM: Alarm

D1、D2、D3: indicator

RD: fuse

K1: time relay power

AQ: start button

AT: high voltage silicon

KV: output voltmeter

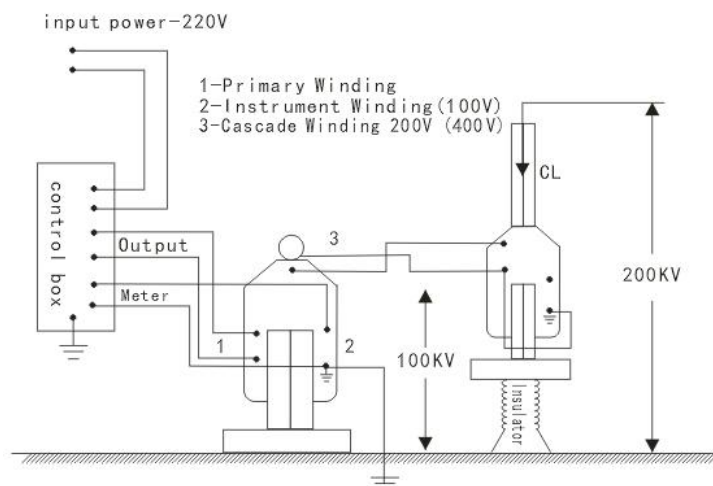

Figure (2)

## V. Instructions

(1) Before the test, the housing of the high voltage test transformer and the grounding end of the power control box should be "⏚"

⏚ "Must be well grounded, otherwise it will endanger the safety of persons and equipment.

(2) Be familiar with the electrical principle wiring diagram of high voltage test transformer and power control box before operation. If the DC voltage and leakage test is checked, the high voltage silicon stack and microammeter can be rotated at the high voltage end of the high voltage test transformer.

(3) When the line is checked, the main power switch can be closed, and the red switch indicator light is also on. If the regulator handle should be counterclockwise back to zero, the red stop button on the indicator light, otherwise the start button refused to close.

(4) Press the start button and the green button indicator lights up, then rotate the regulator handle evenly and slowly at a clockwise speed of 1.5-2 kV per second. The high voltage rises step by step and pays close attention to the voltmeter indication and the test sample until the required test high voltage is set.

(5) In order to test the voltage test time of the product, the timing time required by the timer can be unplugged and the timing and alarm switch can be pressed, that is, the voltage withstand of the product is tested in the specified time, and then the alarm will be informed that if the product is broken down, the overcurrent relay will automatically trip.

(6) If it is necessary to protect the tested product from overvoltage breakdown, the discharge voltage of the protective ball can be adjusted to about 1.15 times of the test voltage by continuously connecting the protective ball gap on the high voltage side.

(7) Schematic diagram of high pressure test:

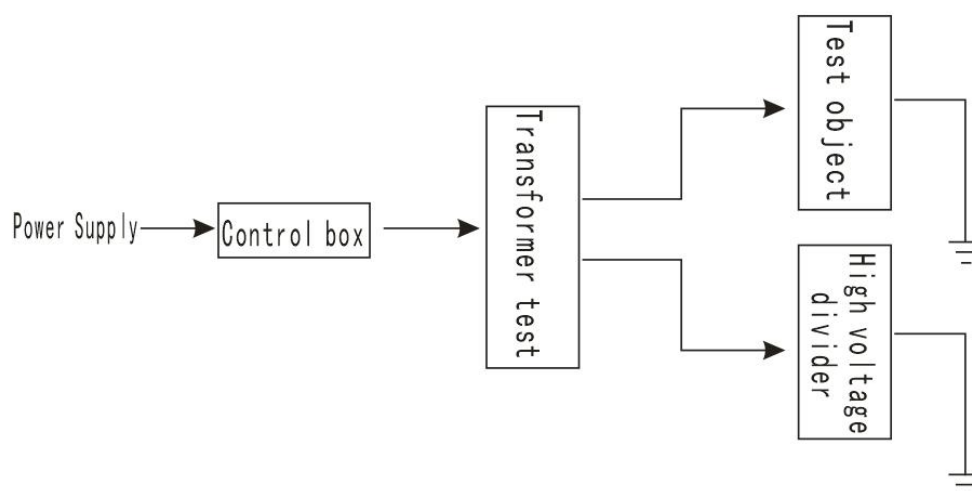

## **VI. Precautions**

- 1、 Safety and Correctness of High Voltage Electrical Insulation Test, In addition to being familiar with this product manual, Must comply with relevant national regulations and standards  
GB/T16927-1996 《High Voltage Test Technology》  
DL/T596-1996 《Procedure for Preventive Test of Electric Power Equipment》
- 2、 In normal high-voltage electrical insulation tests, this series of products are not allowed to exceed the rated output voltage
- 3、 When using this series of products to form a cascade high-voltage test, Pay special attention to checking the condition of the transformer body and insulating support of the 2nd and 3rd stage, correctness of connecting lines, Protective grounding and protective grounding conditions of the entire system

## **VII. Accessories**

Instruction Manual

Product test report

Certificate