

List

I Function features	1
II Technical index	2
IV. Structure and facade	3
1. Instrument facade	3
2. Keyboard description	3
V LCD interface	5
1. Main menu interface	5
2. Parameter setting screen	5
3. Three-phase transformer turns ratio test	6
4. 3-phase turns ratio test	8
5. Single phase transformer test	9
6. Z-type transformer test	10
7. Scott transformer (T-type transformer) test	11
8. Anti-Scott transformer(T-type transformer) test	12
9. History data screen	13
VI Test description:	16
VII Maintenance and charge of battery	19
VIII Attentions:	19

I Function features

1. Input single power, internal digital combination standard sine wave test source output
 2. Phase angle measurement function: measure the phase angle between high voltage side and low voltage side. Measure the turn ratio and angle of “Non integral point” transformer.
 3. It can conduct single-phase measurement and three-phase winding automatic test. Three phase turn ratio value, phase angle value, error, tapping position, tapping value can be measured for once. It also can identify connecting group number automatically.
 4. Testing results can be displayed in the form of digit and hexagon vector diagram, which makes transformer connecting group can be made out obviously.
 5. With blind test function: There is no need to choose connecting method and group. When measuring Y/Δ 、 Δ/Y transformer, no external short-circuit is needed, connecting method can be shifted automatically according to the chosen testing contents.
 6. With tapping test function: TTR and TTR error in the position of each tapping switch can be gauged quickly. Just input rated TTR once, instead of inputting over and over again, TTR error in tapping position can be calculated.
 7. With functions of turns ratio measurement and voltage TTR measurement.
 8. With 5.6 inch LCD, the effect of data & figure display is visualized and fine.
 9. With small size and light weight, it is easy to carry.
 10. With built-in high capacity chargeable lithium battery. Test can be conducted without any power supply on site, and once the battery is charged fully, it can make measurement for more than 500 times continuously.
-

II Technical index

1. TTR measurement range: 0.9~10000.
 2. High measurement speed: three-phase test can be completed within 40 seconds.
 3. Measurement accuracy:
 - Voltage measurement accuracy on HV side: 0.05%
 - Voltage measurement accuracy on LV side: 0.1%
 - Phase angle measurement accuracy: 0.1°
 - TTR measurement accuracy: 0.1% (0.9—200)
 - 0.2% (200—2000)
 - 0.3% (2000—10000)
 4. Volume: 320mm*240mm*130mm.
 5. Weight: 3Kg.
-

IV. Structure and facade

The instrument is made up of host and accessory box. Accessory box is used to place test wires and tools.

1. Instrument facade



Figure 1. Instrument Facade

The upper left: high voltage side and low voltage side, to test terminal.

The bottom left: LCD.

The bottom right: keyboard.

The upper center: printer.

The upper right: grounding terminal, charge port, USB port, RS232 port, operating switch.

2. Keyboard description

There are 30 keys in all, and they are "Save", "Inquire", "Set", "Shift", "↑", "↓", "←", "→", "Soft switch", "Exit", "Enter", "Self-check", "Help", "1", "2"(ABC), "3"(DEF), "4"(GHI), "5"(JKL), "6"(MNO), "7"(PQRS), "8"(TUV), "9"(WXYZ), "0", "."(radix point), "#", auxiliary

function keys “F1”, “F2”, “F3”, “F4”, “F5”.

Corresponding functions of each key are as follows:

“↑”, “↓”, “←”, “→”: Cursor Movement Key. On the main menu, it is used to move cursor to a certain function menu. On the parameter setting screen, “↑” and “↓” is used to shift current option; “←” and “→” is used to change value.

“Enter”: Enter key; on the main menu, press this key namely enter into the chosen function. In addition, when input certain parameters, press “Enter” to start and end this input.

“Exit”: backspace key, when it isn’t under the condition of parameter input, press “Exit” all can return to the main menu directly.

“Save”: to save testing results as records.

“Inquire”: to scan the saved records.

“Set”: press this key on the main menu, to enter into parameter setting screen.

“Shift”: it’s used by manufacturer when ex-factory commissioning is made, and user doesn’t need to use it.

“Self check”: keep this function(standing off).

“Help”: to display help information.

“digit(character)”: to input setting parameters (can input digit or character).

“Radix point”: it is used to input radix point, when setting parameter.

“# ”: keep this function(standing off).

“F1”, “F2”, “F3”, “F4”, “F5”: auxiliary function keys, to enter into auxiliary function interface or to start corresponding functions.

V LCD interface

There are nine screens on LCD interface, which includes main menu and ten function interfaces. The 9th screen is an alternate option.

1.Main menu interface

As shown in figure 3.

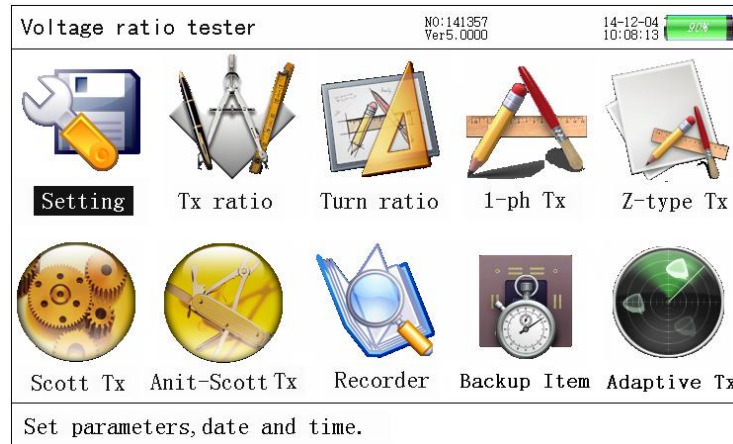

Figure 3. Main menu

When the tester is started up, the main menu will be displayed as shown in figure 3. There are ten function options, Setting, Tx ratio, Turn ratio, 1-ph Tx, Z-type Tx, Scott Tx, Anti-Scott Tx, Recorder, Backup Item, Adaptive Tx. which can be chosen by pressing “↑”, “↓”, “←”, “→”, and the chosen item will be displayed highlightedly, then press “Enter” to enter into corresponding function; State parameters is displayed at the top of screen, including program version No., date, time etc. Voltage amplitude and residual capacity of internal battery are displayed at the top of screen at the same time, in order that operator can observe the state of instrument battery at any time. In case finds battery with insufficient voltage, he can charge it timely; Prompts bar is located at the bottom of screen, which is aimed at providing simple operation prompts to user, so that user can operate it correctly.

2. Parameter setting screen

Press “parameter setting”function, enter into the screen of parameter setting at first, as shown in figure 4.

The items, need to be set on the parameter setting screen, include testing sample No., rated turns ratio, tapping amount, equal tapping level, date setting, time setting etc..Prompts bar is located at the bottom of LCD, to prompt operator how to operate. On the interface as shown in figure 4, press “↑” and “↓” to move cursor; press “Enter”, then

the color of chosen parameter will be changed, at this time press digit key to input required parameters and press “Enter”, the setting parameter take effect and color of the parameter items return to normal; after parameter setting, press “Exit” to return. The meaning and function of each parameter item are as follows:

- Testing sample No.: the No.of transformer (to be tested), it can be input not more than 6 digits.
- Rated TTR: at rated gear, the voltage turns ratio value of transformer (to be tested) on the high voltage side and low voltage side.
- Equal tapping level: voltage percent regulated at each gear of transformer.
- Date setting: to set current date.
- Time setting: to set current time.

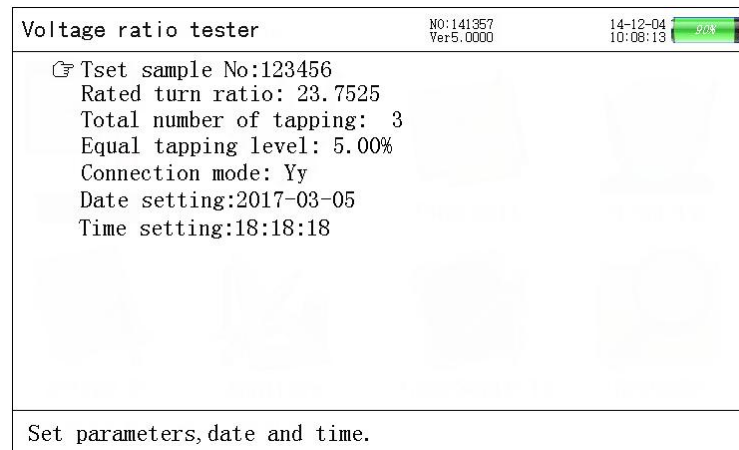

Figure 4. Parameter setting screen

3. Three-phase transformer turns ratio test

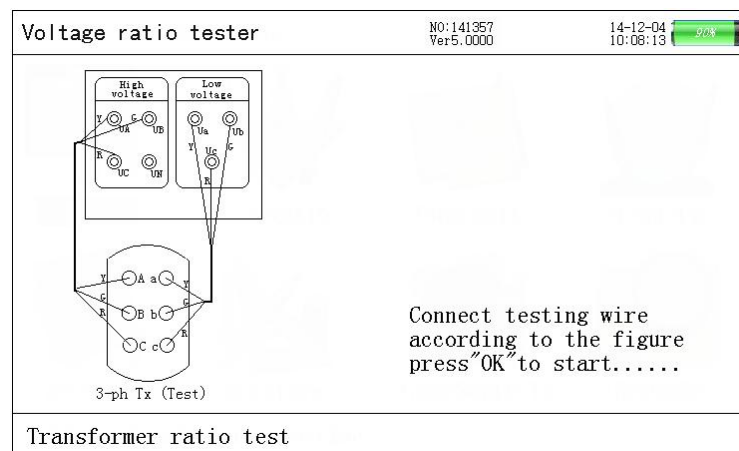

Figure 5. Prompts screen of 3-phase TTR test connection

Set parameter before 3-phase transformer turns ratio test. Press “Set” or choose “Parameter setting” item, then press “Enter” to parameter setting screen, after parameter setting, press “Exit” to return to main menu interface, choose “3-phase transformer turns ratio test” item and press “Enter” to connection prompts screen (as shown in figure 5). Detailed connection diagram is displayed on the screen, so that operator can connect wire according to the shown diagram.

After connection, press “Enter” to test automatically. When the automatic counting of test is up to 57 times, the counting will cease automatically. At the time, testing is over and its results will be displayed. Screen of prompts bar and testing results is shown as figure 6.

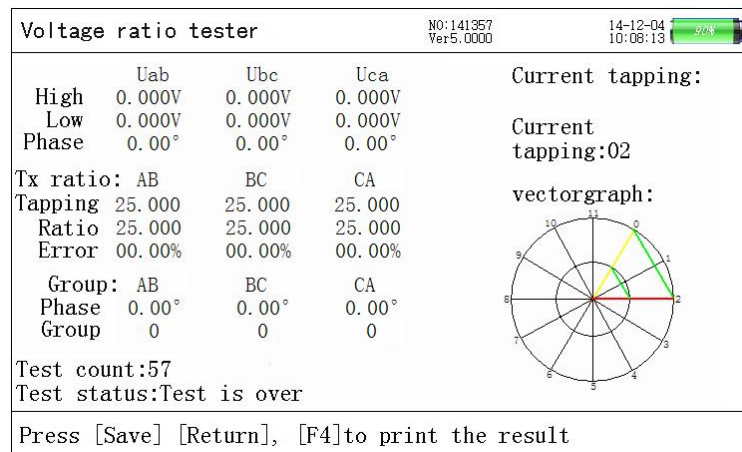

Figure 6. Screen of 3-phase transformer turns ratio testing results

After testing, its result will be displayed on LCD, as shown in figure 6: data of testing is displayed on the left side of screen, including 3-phase voltage value on the HV side, 3-phase voltage value on the LV side, phase angle between 3-phase HV and LV(the above items are the data of testing process), current tapping TTR value of each phase, 3-phase actual measuring rated TTR, error percent of 3-phase TTR, group judgment, times of testing count, and testing state. Vector diagrams of each setting parameter and group are displayed on the right side of screen, as shown in figure 6: when the current group is zero point, angle and direction of HV side vector diagram(see figure 6: big triangle in the outer ring) coincide with LV side vector diagram(see figure 6: big triangle in the inner ring). After testing, press “Save” to store testing results. Press “Exit” to return; press “Enter” to test again.

4. 3-phase turns ratio test

Set parameter before 3-phase turns ratio test. Press “Set” or choose “Parameter setting” item, then press “Enter” to parameter setting screen, after parameter setting, press “Exit” to return to main menu interface, choose “3-phase turns ratio test” item and press “Enter” to connection prompts screen (as shown in figure 7). Detailed connection diagram is displayed on the screen, so that operator can connect wire according to the shown diagram.

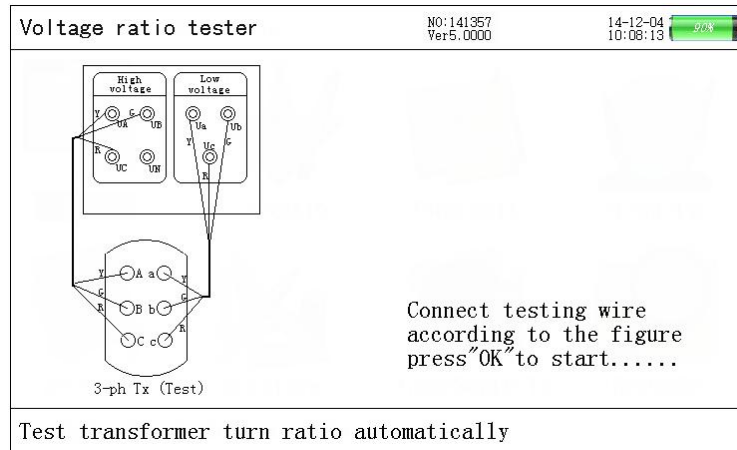

Figure 7. Connection prompts screen of 3-phase turns ratio

After connection, press “Enter” to test automatically. When the automatic counting of test is up to 42 times, the counting will cease automatically. At the time, testing is over and its results will be displayed. Screen of prompts bar and testing results is shown as figure 8.

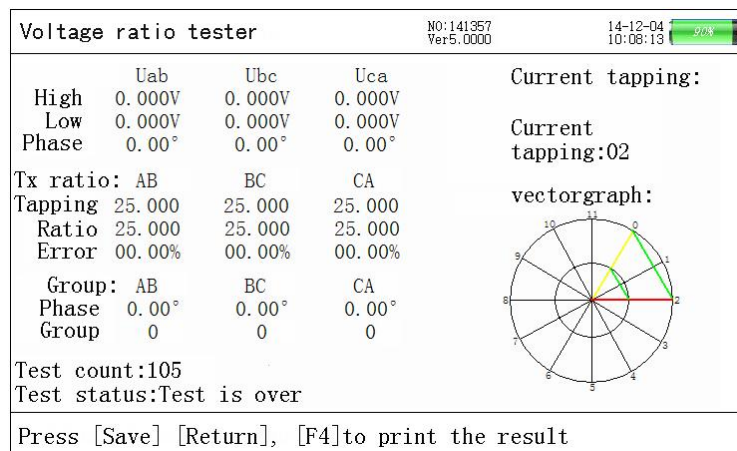

Figure 8. Screen of 3-phase turns ratio testing results

After testing, its result will be displayed on LCD, as shown in figure 8: data of

testing results is displayed on the left side of screen, including 3-phase voltage value on the HV side, 3-phase voltage value on the LV side, phase angle between 3-phase HV and LV(the above items are the data of testing process), current tapping TTR value of each phase, 3-phase actual measuring rated TTR, error percent of 3-phase TTR, group judgement, times of testing count, and testing state. Each setting parameter is displayed on the right side of screen. After testing, press “Save” to store testing results. Press “Exit” to return; press “Enter” to test again.

5. Single phase transformer test

Set parameter before single phase transformer test. After parameter setting, press “Exit” to return to main interface, choose “single phase transformer test” item and press “Enter” to connection prompts screen (as shown in figure 9), connect wire according to the shown diagram.

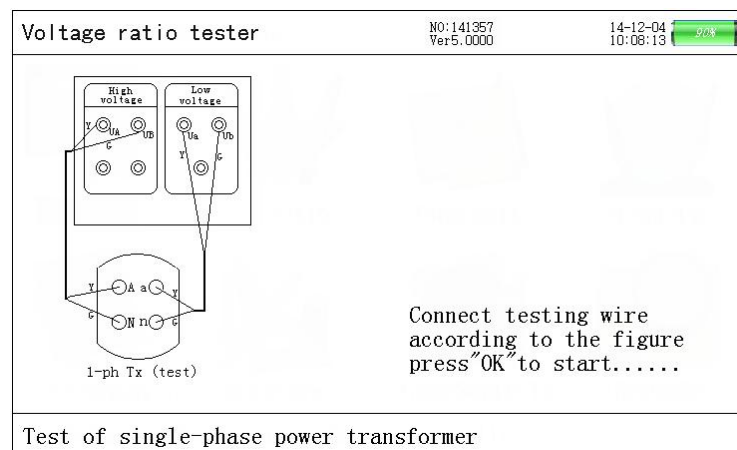

Figure 9. Connection prompts screen of single phase transformer test

After connection, press “Enter” to test automatically. When test counting is up to 25 times, the counting will cease. At the time, testing is over. Screen of prompts bar and testing results is shown as figure 10. In the process of testing, prompts bar indicates “single phase power transformer turns ratio, polarity test”. After testing, its results will be displayed on LCD, as shown in figure 10. Testing results include single phase voltage on HV side, single phase voltage on LV side, actual measuring phase angle, single phase rated TTR, single phase test TTR, error of single phase TTR, group judgement, test counting, test state. After testing, press “Save” to store testing results. Press “Exit” to return, and press “Enter” to test again.

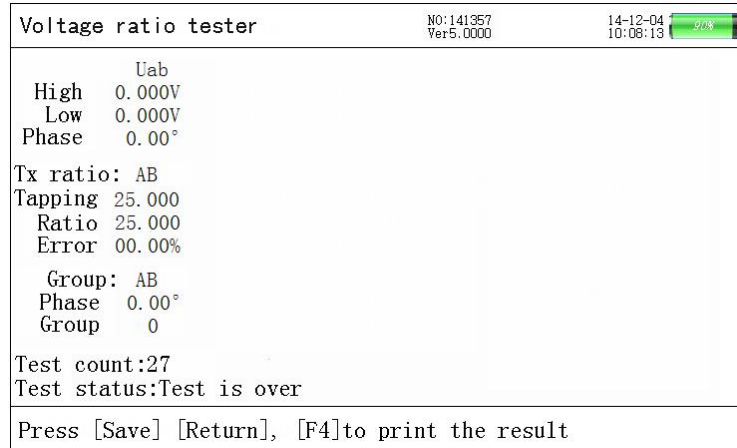

Figure 10 Screen of single phase transformer connection results

6. Z-type transformer test

Set parameter before Z-type transformer test. After parameter setting, press “Exit” to return to main interface, choose “Z-type transformer test” item and press “Enter” to connection prompts screen (as shown in figure 11), connect wire according to the shown diagram. After connection, press “Enter” to “Z-type transformer” testing screen. At the time, the instrument starts to test automatically. When testing is over, its results will be displayed on screen. Screen of prompts bar and testing results is shown as figure 12.

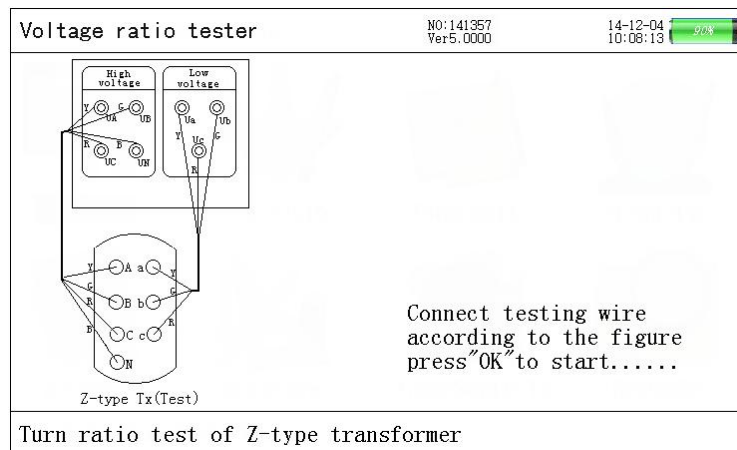

Figure 11. Prompts screen of Z-type transformer testing connection

After testing, its result will be displayed on LCD, as shown in figure 12. Left side of the screen includes 3-phase voltage and phase on the HV side, 3-phase voltage and phase on the LV side, tapping value, transformer turns ratio, group judgement, counting times of test, and test state. Right side includes setting parameter and vector analysis chart. Press “Save” to store testing data; press “Exit” to return, and press “Enter” to test

again according to the information of prompts bar.

Voltage ratio tester				NO:141357 Ver5.0000		14-12-04 10:08:13		92%	
High	UAN	UBN	UCN						
Voltage	0.000V	0.000V	0.000V						
Phase	0.00°	0.00°	0.00°						
Low :	Uac	Uba	Ucb					Current tapping:02	
Voltage	0.000V	0.000V	0.000V						
Phase	0.00°	0.00°	0.00°						
Tx ratio	UAN/Uac	UBN/Uba	UCN/Ucb						
Tapping	25.000	25.000	25.000						
Ratio	25.000	25.000	25.000						
Error	0.00%	0.00%	0.00%						
Group:	A	B	C						
Phase	30.00°	30.00°	30.00°						
Group	1	1	1						
Test count:57									
Test status:Test is over									
Press [Save] [Return], [F4] to print the result									

Figure 12. Screen of Z-type transformer connection results

7. Scott transformer (T-type transformer) test

Set parameter before Scott transformer test. After parameter setting, press “Exit” to return to main interface, choose “Scott transformer test” item and press “Enter” to connection prompts screen (as shown in figure 13), connect wire according to the shown diagram. After connection, press “Enter” to “Scott transformer” testing screen. At the time, the instrument starts to test automatically. When testing is over, its results will be displayed on screen. Screen of prompts bar and testing results is shown as figure 14.

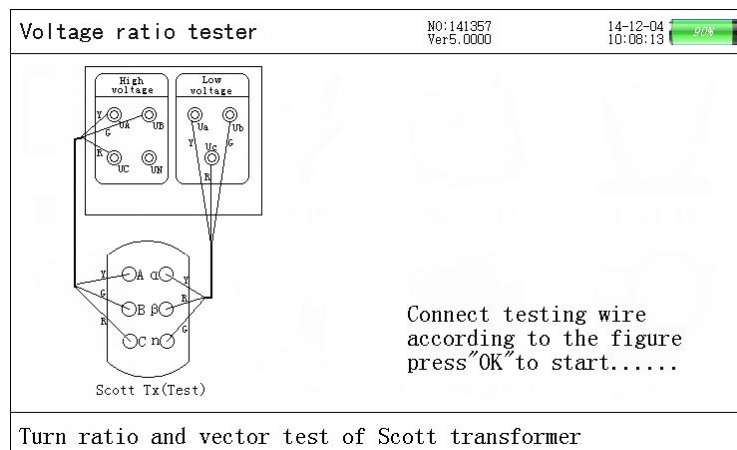

Figure 13 Prompts screen of Scott transformer test connection

After testing, its result will be displayed on LCD, as shown in figure 14. Left side of the screen includes 3-phase voltage and phase on the HV side, 2-phase voltage and phase on the LV side, tapping value, transformer turns ratio, error of TTR, group

judgment, counting times of test, and test state. Right side includes setting parameter value and low voltage angle. Press “Save”, “Exit”, “Enter” to test again., according to the information of prompts bar.

Voltage ratio tester			NO:141357 Ver5.0000		14-12-04 10:08:13 	
High :	UAB	UBC	UCA			
	0.000V	0.000V	0.000V			
	0.00°	0.00°	0.00°			
Low :	Uax		Uby	Current		
	0.000V		0.000V	tapping:02		
	0.00°		0.00°	Low_Angle:		
Tapping :	UAB/Uax		UCA/Uby	∠xy=45°		
Tapping	25.000		25.000			
Ratio	25.000		25.000			
Error	0.00%		0.00%			
Group :	UAB/Uax		UCA/Uby			
Phase	30.00°		30.00°			
Group	1点		1点			
Test count:42						
Test status:Test is over						
Press [Save] [Return], [F4]to print the result						

Figure 14. Screen of Scott transformer testing results

8. Anti-Scott transformer(T-type transformer) test

Set parameter before Anti-Scott transformer test. After parameter setting, press “Exit” to return to main interface, choose “Anti-Scott transformer test” item and press “Enter” to connection prompts screen (as shown in figure 15), connect wire according to the shown diagram.

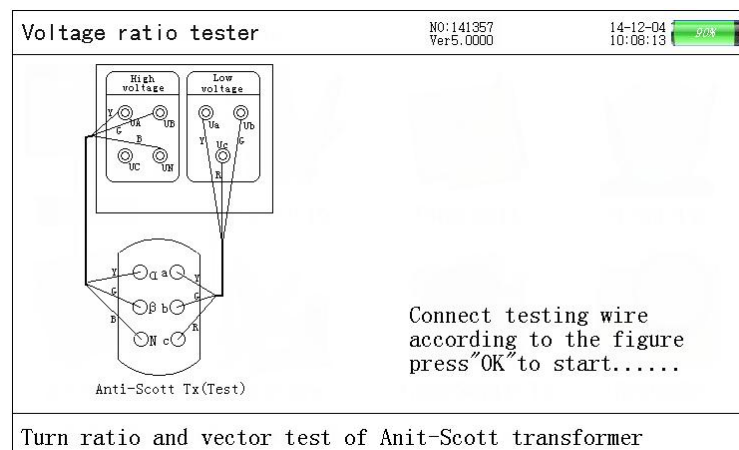

Figure 15. Prompts screen of Anti-Scott transformer test connection

After connection, press “Enter” to “Anti-Scott transformer”testing screen. At the time, the instrument starts to test automatically. When testing is over, its results will be displayed on screen. Screen of prompts bar and testing results is shown as figure 16. After testing, its result will be displayed on LCD, as shown in figure 16. Left side of the

screen includes 3-phase voltage and phase on the HV side, 2-phase voltage and phase on the LV side, phase, tapping value, transformer turns ratio, error of TTR, group judgement, counting times of test, and test state. Right side includes setting parameter value and low voltage angle. Press “Save”, “Exit”, “Enter” to test again according to the information of prompts bar.

Voltage ratio tester				No:141357 Ver5.0000	14-12-04 10:08:13 
High	: U α N		U β N		
	0.000V		0.000V		
	0.00°		0.00°		
Low	: Uab	Ubc	Uca	Current	
	0.000V	0.000V	0.000V	tapping:02	
	0.00°	0.00°	0.00°		
Ratio	: U α N/Uab	U β N/Ubc	U α N/Uca		
Tapping	25.000	25.000	25.000		
Ratio	25.000	25.000	25.000		
Error	0.00%	0.00%	0.00%		
Group	: U α N/Uab	U β N/Ubc	U α N/Uca		
Phase	30.00°	30.00°	30.00°		
Group	03	03	03		
Test count:42					
Test status:Test is over					
Press [Save] [Return], [F4] to print the result					

Figure 16. Screen of Anti-Scott transformer testing results

9. History data screen

Press “Inquire” or choose “History data” item on main menu to history data screen. The screen displays 3-phase transformer turns ratio data which has been measured and recorded. It includes total number of data, current data sequence, record time and date, test sample No., total number of tapping, equal tapping level, rated transformer turns ratio, TTR tapping value, TTR value, error, angle, group etc., as shown in figure 17.

The content of prompts bar includes “ \uparrow ”, “ \downarrow ”(turn page), “F2”(save in U disk), “F3”(delete), “F5”(upload data).

Voltage ratio tester				No:141357 Ver5.0000	14-12-04 10:08:13 
Sum:007	No:001	2017-03-04 16:22:55			
Serial Num:123456	Number of tapping:03				
Equal tapping level: 5.0%	Rated turn ratio:23.753				
Result	: AB	BC	CA		
Tapping	23.753	23.753	23.753		
Ratio	23.6209	23.6526	23.8092		
Error	-0.554%	-0.421%	+0.239%		
Angle	-0.07°	-0.07°	-0.07°		
Group	0	0	0		
Press [F2] to USB, [F3] to Delete, [F4] to print					

Figure 17. History data inquire

10. Adaptive Tx test

This function is used to test transformers with very low rated voltages on the high voltage side. Due to the low primary voltage of this type of transformer, the excitation current will be high during the test, and using conventional test voltages sometimes exceeds the range of currents that can be supplied. Therefore the test is to be carried out using a reduced test voltage. In the main interface, select the "low-voltage special test" option and press the [↵] key to enter the wiring prompt screen shown in Figure 18, the operator must be wired in accordance with the diagram.

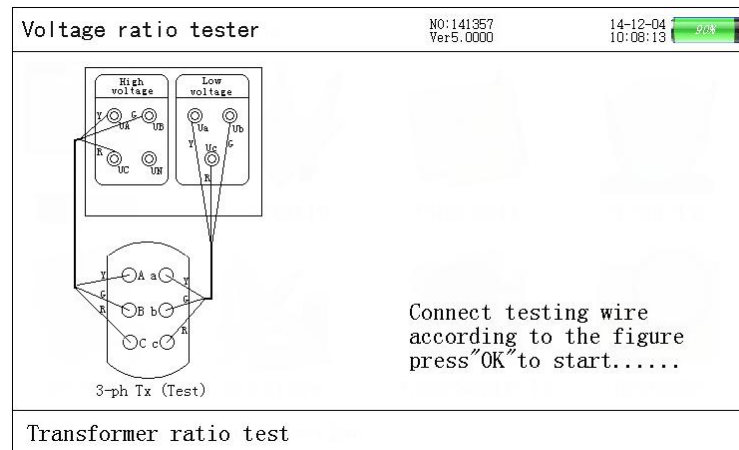

Figure 18. Adaptive Tx test connection

After connection, press "Enter" to test automatically. When the automatic counting of test is up to 57 times, the counting will cease automatically. At the time, testing is over and its results will be displayed. Screen of prompts bar and testing results is shown as figure 19.

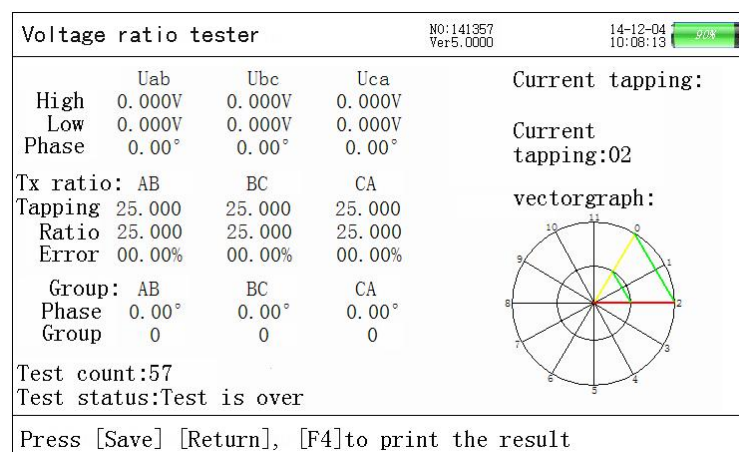

Figure19. Adaptive Tx test testing results

After testing, its result will be displayed on LCD, as shown in figure 19: data of testing is displayed on the left side of screen, including 3-phase voltage value on the HV side, 3-phase voltage value on the LV side, phase angle between 3-phase HV and

LV(the above items are the data of testing process), current tapping TTR value of each phase, 3-phase actual measuring rated TTR, error percent of 3-phase TTR, group judgment, times of testing count, and testing state. Vector diagrams of each setting parameter and group are displayed on the right side of screen, as shown in figure 19: when the current group is zero point, angle and direction of HV side vector diagram(see figure 19: big triangle in the outer ring) coincide with LV side vector diagram(see figure 19: big triangle in the inner ring). After testing, press "Save" to store testing results. Press "Exit" to return; press "Enter" to test again.

VI Test description:

For common type 3-phase transformer, choose “turns ratio measurement” function; for “Non integral point”(angle value isn't integer multiple of 30°) 3-phase transformer (for example: rectification transformet, electrical stove transformer, traction transformer etc.), choose “voltage ratio measurement” function; for single phase transformer, choose “single phase TTR” testing function.

1. For 3-phase measurement, three wires(with color of yellow, green and red) on the HV side of instrument connect to A, B,C on the HV side of transformer respectively; three wires(with color of yellow, green and red) on the LV side of instrument connect to a, b, c on the LV side of transformer respectively. Connection diagram is shown as follows:

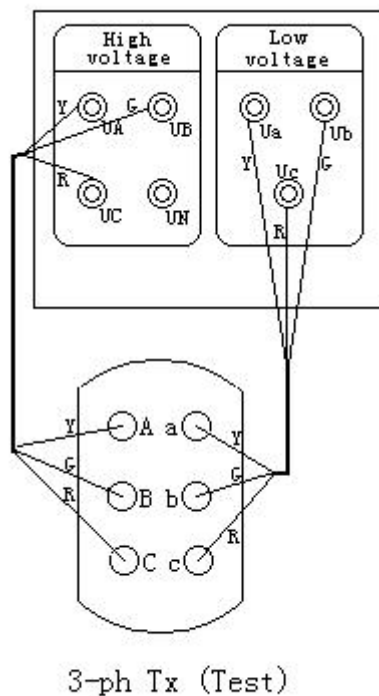

Figure 18. 3-phase transformer test connection

2. For single phase measurement, two wires (with color of yellow and green) on the HV side of instrument connect to A, N on the HV side of single phase transformer respectively; two wires (with color of yellow and green) on the LV side of instrument connect to a, n on the LV side of transformer respectively. Only if the connection is correct, test can be conducted. Connection diagram is shown as follows:

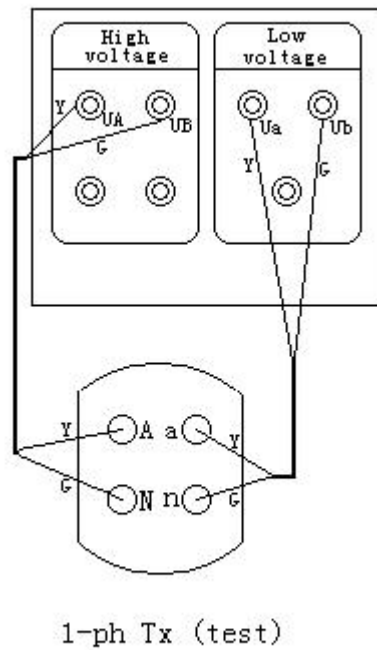

Figure 19. Single phase transformer test connection

3. For Z-type transformer measurement, four wires (with color of yellow, green, red and black) on the HV side of instrument connect to A, B, C, N on the HV side of transformer respectively; four wires (with color of yellow, green, red and black) on the LV side of instrument connect to a, b, c on the LV side of transformer respectively. Only if the connection is correct, test can be conducted. Connection diagram is shown as follows:

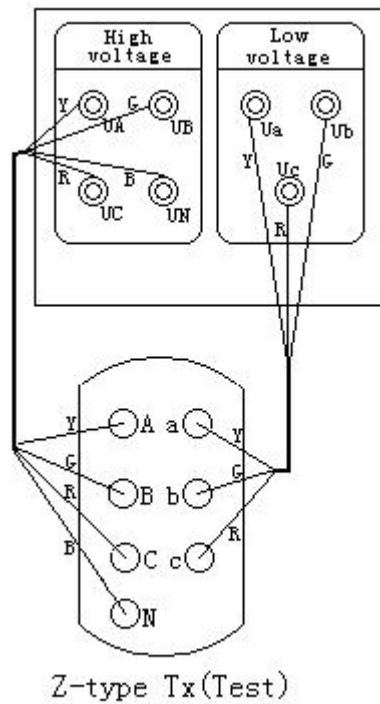

Figure 22. Z-type transformer test connection

VII Maintenance and charge of battery

High-performance Li-ion chargeable battery is adopted by the instrument as internal electric source, in order to avoid damage to the instrument due to incompatibility of electrical level, operator can not replace it with other type battery randomly.

The instrument shall be charged timely, so that battery life can not be affected by deep discharge of battery.

When it is used under normal working condition, the instrument should be charged every day (if it hasn't been used for a long time, charging it once within one month is best.), which can keep battery usage and life from bad effect. Every charge time should be above 6 hours. Charge protection function of battery can charge the instrument continuously.

When battery is taken out of instrument, battery protection panel (inside instrument) will enter into protection state. The instrument can not work directly after battery is installed, thus charger should be used to remove protection state, at the time, the instrument can operate normally.

VIII Attentions:

1. Before measurement, make sure test sample is in the state of outage and all calibrating terminals don't contact with earth.
 2. Measuring connection must be operated according to instructions strictly, otherwise any serious consequences should be born by yourself.
 3. Before measurement, setting parameter must be checked seriously.
 4. Power socket with earth wire is the best choice for charging.
 5. Over capacity working is forbidden.
 6. Converse connection of high voltage and low voltage is forbidden.
-